

CILINDROS: 10, 20, 25, 35, 40, 60 Y 100 lb.

NORMA(S) DE REFERENCIA: **RTCA 23.01.29:05, COD. 49 CFR 178 (US DOT)**

- A. ALTURA TOTAL
- B. ALTURA DEL CUELLO PROTECTOR
- C. DIÁMETRO DEL CUELLO PROTECTOR
- D. DIÁMETRO DEL CILINDRO
- E. ALTURA DE LA BASE DE SUSTENTACIÓN
- F. DIÁMETRO DE LA BASE DE SUSTENTACIÓN

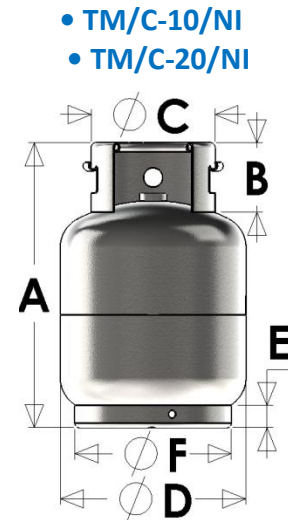
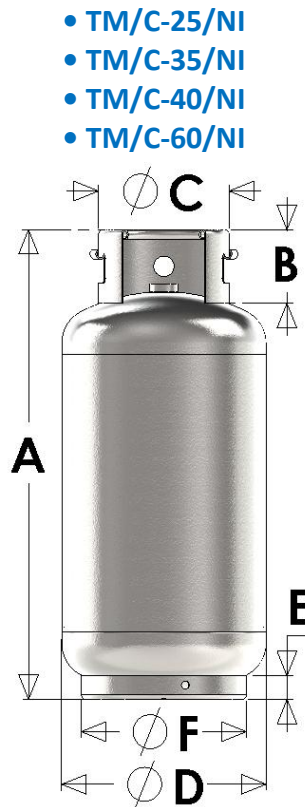
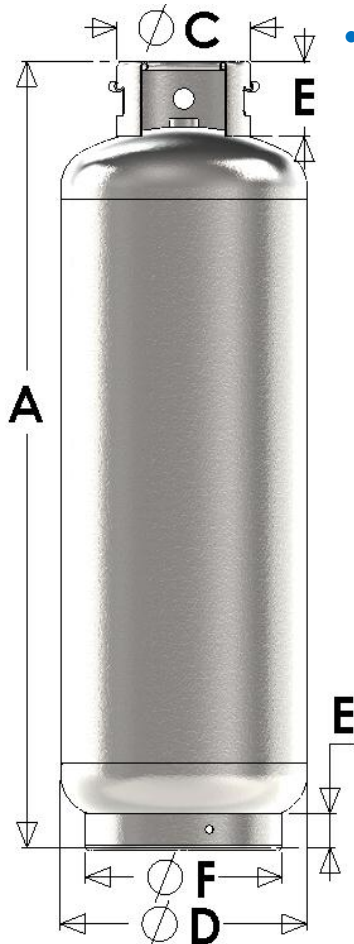

DIMENSIONES GENERALES (mm)

MODELO	Capacidad G.L.P kg. (lb)	A	B	ØC	ØD	E	ØF	Capacidad Volumétrica (dm ³)	Tara Teórica (kg)
TM/C-10/NI	4.5 (10 lb)	400	115	200	254	46	220	11.16	6.7
TM/C-20/NI	9.1 (20 lb)	469	115	200	305	37	257	22.25	9.6
TM/C-25/NI	11.3 (25 lb)	509	115	200	317	37	257	26.98	11.1
TM/C-35/NI	15.9 (35 lb)	656	115	200	317	37	257	38.27	13.5
TM/C-40/NI	18.1 (40 lb)	729	115	200	317	37	257	43.89	15.2
TM/C-60/NI	27.2 (60 lb)	1009	115	200	317	37	257	65.38	22.1
TM/C-100/NI	45.4 (100 lb)	1201	115	200	376	57	300	109.53	31.3